

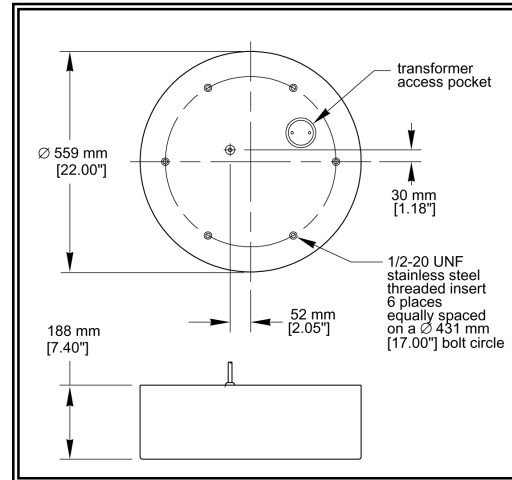

odomhydrographic.com

Odom Hydrographic Systems, Inc.
 1450 Seaboard Avenue
 Baton Rouge, LA. 70810 -6261
 225.769.3051, Facsimile 225.766.5122

HM10-17



Performance Data

Frequency	10kHz
Beam Width	16°
Q (transmit)	4
Rated RMS Power	6,000 W
Balanced Impedance	50 ohms
Peak Figure of Merit	-2
Bandwidth	
Acoustic Window Material	Urethane
Cable Type	AWL5MP underwater connector
Cable Size	10mm
Weight	114Kg..

The M187 has a low frequency, narrow beam, ceramic array for exceptional deep water performance and evaluation of the sub-bottom. The SEALCAST™ housing ensures durability and reliability. The robust, internal, stainless steel chassis provides six threaded mounting points.

M187_information_sheet

Hull Mount, 10khz-17d, M187-1, 5P-3F-SUB