

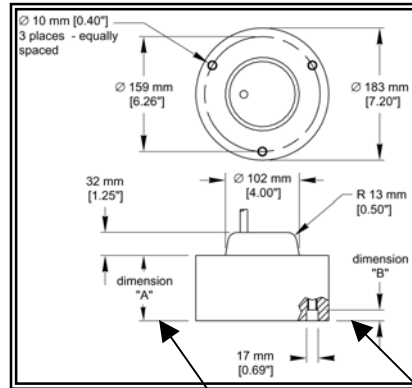

odomhydrographic.com

Odom Hydrographic Systems, Inc.  
 1450 Seaboard Avenue  
 Baton Rouge, LA. 70810 -6261  
 225.769.3051, Facsimile 225.766.5122

## TM200-3



Frequency	Dimension "A"	Dimension "B"
33, 200	90mm (3.56")	15mm (0.59")
24	118mm (4.65")	43mm (1.68")

### Performance Data

Frequency	200kHz
Beam Width	3°
Q (transmit)	18
Rated RMS Power	3,000 W
Balanced Impedance	60 ohms
Peak Figure of Merit	-3
Bandwidth	
Acoustic Window Material	Urethane
Cable Type	C43 (2-14 AWG)
Cable Size	10mm
Weight	8Kg.

The M192 multi-element arrays provide high transmitting and receiving voltage response resulting in excellent target detection. The low transmit Q is designed for good shallow water performance.